

## INSTALLATION AND MAINTENANCE INSTRUCTIONS

# RMK400 Recessed Mounting Kit for use with 100 and 200 Photoelectronic or 400 and 500 Series Plug-in Detectors



A Division of Pittway  
3825 Ohio Avenue, St. Charles, Illinois 60174  
1-800-SENSOR2, FAX: 630-377-6495

**NOTICE:** This manual should be left with the owner/user of this equipment.

### General Description

The RMK400 Recessed Mounting Kit is designed for use with System Sensor 100 and 200 photoelectronic or 400 and 500 Series plug-in detectors. As indicated in Figure 1, this mounting kit provides for the recessed mounting of these detectors on a junction box with flexible conduit on dry-wall, suspended ceilings, and other similar surfaces.

**Note:** All System Sensor smoke detectors can be made tamper-resistant. However, the use of this capability is NOT recommended with the RMK400 Mounting Kit.

The kit consists of:

- 1 Plastic Recess Mounting Ring
- 1 Plastic Spacer Ring
- 1 Metal Mounting Bracket
- 2 Screws, Type B, No. 8

### Mounting Instructions

1. Cut a 4-1/2-inch (115 mm) hole at the desired location in the mounting surface.
2. Position a 4-1/2 inch junction box at the location of the hole cut in step 1. Route all wiring to the box through flexible conduit. Be sure to allow sufficient conduit and wiring to permit the wired box/conduit assembly to be pulled through the 4-1/2" hole.
3. Pull the wiring through the box and attach the conduit to the junction box.
4. Pull the junction box as far as possible through the hole that was cut in step 1.
5. Attach the Metal Mounting Bracket to the junction box, using the screw supplied with the junction box.
6. Pull the electrical wiring around the Metal Bracket and through the center holes in the Recess Mounting Ring, Spacer Ring, and the Detector Mounting Base. See Figure 2. Align the holes in the B401 or B501 Detector Mounting Base and the holes in the plastic Recess Mounting Ring with the two small holes of the Metal Mounting Bracket.
7. **100/200 Series photoelectronic detectors only.** Snap the Spacer Ring into place in the Recess Mounting Ring.
8. Start the two Type B, No. 8 screws, supplied, into the

**Figure 1:**

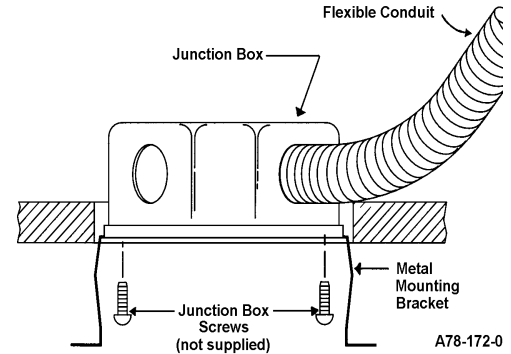

**Figure 2. Top view of mounting bracket:**

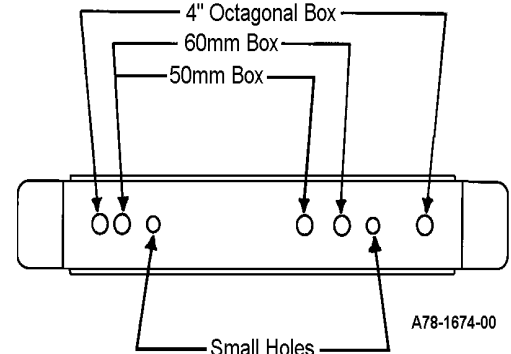

**Figure 3:**

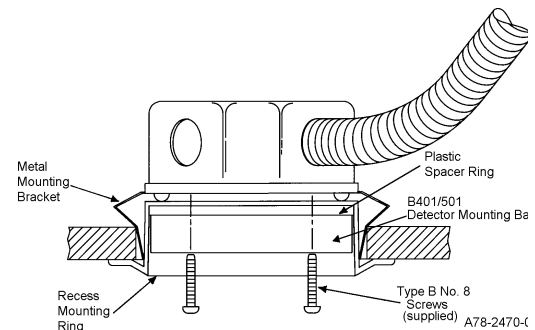

small holes in the Metal Mounting Bracket and tighten them until the assembly is just snug. Do NOT tighten the screws to the point where the Metal Mounting Bracket begins to deform.

9. Insert this assembly into the mounting hole and hold it in place while tightening the screws started in step 8 until the assembly is retained in the mounting surface.
10. Wire the detector base, following the instructions provided with the base.
11. Plug the detector into the base and rotate it clockwise until it locks into the mounting base.