

## RTC Remote Test Coil Kit for use with the B404B and B404BT Bases

### Specifications

|                              |                               |
|------------------------------|-------------------------------|
| Dimensions:                  | 6.6"H x 2.75"W x 1.5"D        |
| Weight:                      | .11 lb.                       |
| Power Requirements           |                               |
| Alarm LED:                   | 2.8 - 32 VDC, 10 mA max.      |
| Test Coil:                   | 15.5 - 32 VDC, 95 mA max.     |
| Total Current:               | 105 mA max.                   |
| Test Switch:                 | 10 VA @ 32 VDC                |
| Reset Switch:                | 10 VA @ 32 VDC                |
| Alarm Response Time:         | 40 seconds max.               |
| Operating Temperature Range: | -10°C to 60°C (14°F to 140°F) |
| Humidity:                    | 95% RH, noncondensing         |

**NOTICE:** This manual should be left with the owner/user of this equipment.

**Figure 1:**

### General Description

The System Sensor Model RTC Remote Test Coil Kit allows for the remote testing of duct detectors using the B404B or B404BT bases that are installed in inconvenient or difficult-to-reach locations. Model RTC can be installed in almost any convenient location and can be attached to a standard 2" X 4" electrical box.

The National Fire Protection Association has published standards and practices for the installation and use of this device. As a result, System Sensor recommends that the installer be familiar with these standards and practices, local codes, and any special requirements of the authority having jurisdiction.

### RTC Contents

- 1 RTS451 Remote Test Station
- 2 #8 x 1/4" pan head screws for mounting bracket
- 1 Test Coil/Replacement Ring
- 1 Screw Pack (2 mounting Assembly screws)
- 1 Jumper with spade lugs
- 1 M02-04 Test Magnet

A78-1995-00

### Installation

Installation of the Model RTC consists of attaching the test station to the mounting surface, mounting the test coil on the detector, and routing the necessary wiring between them. This installation procedure assumes that the associated detector base is already installed and ready for operation.

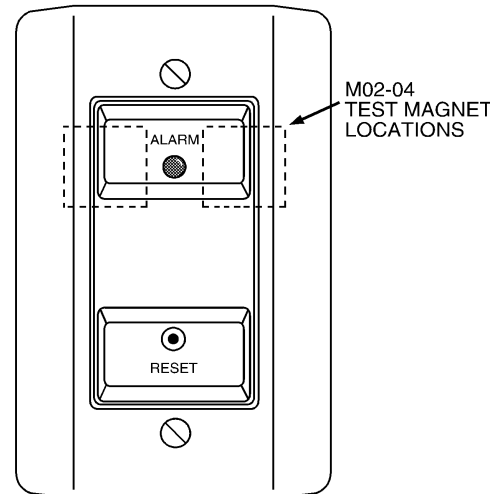

### A. Test Coil Mounting

1. Remove the decorative ring from the B404B/B404BT base by rotating it in either direction to release the hooks. Separate the ring from the base.
2. Position the Test Coil/Replacement Ring Assembly on the base, as shown in Figure 2. Be sure to position the test coil directly over the 4-Position Terminal Block. Otherwise, the coil may not activate the switch during a test.
3. Route the the Test Coil/Replacement Ring Assembly wires through the slot in the base as indicated in Figure 2.
4. Rotate the ring in either direction until it snaps in place. Dress all wiring, as needed.

### B. Wiring

1. Route four wires from the B404B/B404BT to the test station mounting location. Be sure to comply with all applicable electrical codes when installing this wiring. This includes selecting the proper wire size and routing through conduit, if necessary.
2. Connect the wiring to the B404B/B404BT Base and RTS451 Test Station, as shown in Figure 3.

### C. Test Station Mounting

Attach the test station to a standard 2" X 4" electrical box, using the screws supplied with the box.

## Operation

### Test

Position the painted side of the test magnet on the RTS451 Test Station on either the left or right side of the LED as shown in Figure 1. The LED should light within 40 seconds, indicating that the detector being is latched in alarm.

### Reset

Reset the detector by inserting a narrow bladed pocket screwdriver, or other similar tool, into the RESET hole on the front of the test station. Gently press until the LED turns off.

**Figure 2. Ring Replacement:**

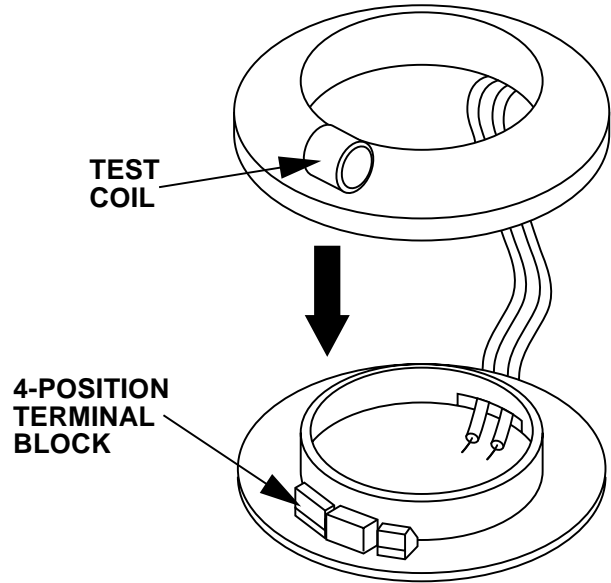

A78-2513-00

**Figure 3. RTC Wiring Diagram:**

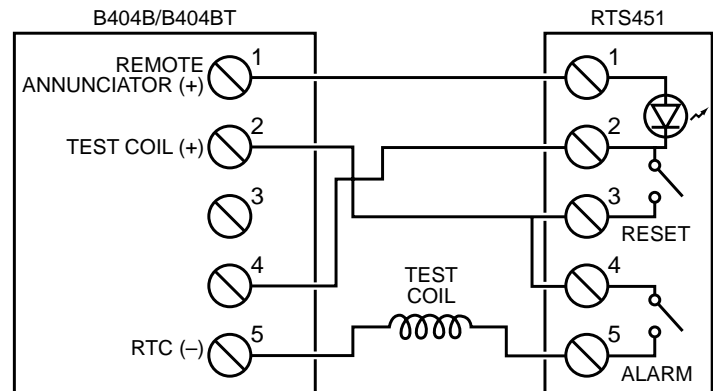

## Three-Year Limited Warranty

System Sensor warrants its enclosed remote test coil to be free from defects in materials and workmanship under normal use and service for a period of three years from date of manufacture. System Sensor makes no other express warranty for this remote test coil. No agent, representative, dealer, or employee of the Company has the authority to increase or alter the obligations or limitations of this Warranty. The Company's obligation of this Warranty shall be limited to the repair or replacement of any part of the remote test coil which is found to be defective in materials or workmanship under normal use and service during the three year period commencing with the date of manufacture. After phoning System Sensor's toll free number 800-SENSOR2 (736-7672) for a Return Authorization number, send defective units postage prepaid to: System Sensor, Repair Depart-

ment, RA # \_\_\_\_\_, 3825 Ohio Avenue, St. Charles, IL 60174. Please include a note describing the malfunction and suspected cause of failure. The Company shall not be obligated to repair or replace units which are found to be defective because of damage, unreasonable use, modifications, or alterations occurring after the date of manufacture. In no case shall the Company be liable for any consequential or incidental damages for breach of this or any other Warranty, expressed or implied whatsoever, even if the loss or damage is caused by the Company's negligence or fault. Some states do not allow the exclusion or limitation of incidental or consequential damages, so the above limitation or exclusion may not apply to you. This Warranty gives you specific legal rights, and you may also have other rights which vary from state to state.