

CR-6 Six Relay Control Module

SPECIFICATIONS

Normal Operating Voltage:	15-32 VDC
Stand-By Current:	1.45 mA
Alarm Current:	32 mA (assumes all six relays have been switched once and all six LEDs solid on)
Temperature Range:	32°F to 120°F (0°C to 49°C)
Humidity:	10 to 93% Non-condensing
Dimensions:	6.8"H × 5.8"W × 1.0"D
Accessories:	BB-2 Cabinet; BB-6 Cabinet; CH-6 Chassis
Wire Gauge:	12-18 AWG
Relay Current:	30 mA/Relay Pulse (15.6 mS pulse duration) pulse under panel control

RELAY CONTACT RATINGS:

CURRENT RATING	MAXIMUM VOLTAGE	LOAD DESCRIPTION	APPLICATION
3 A	30 VDC	Resistive	Non-coded
2 A	30 VDC	Resistive	Coded
.9 A	110 VDC	Resistive	Non-coded
.9 A	125 VDC	Resistive	Non-coded
.5 A	30 VDC	Inductive (L/R = 5ms)	Coded
1 A	30 VDC	Inductive (L/R = 2ms)	Coded
.3 A	125 VAC	Inductive (PF = .35)	Non-coded
1.5 A	25 VAC	Inductive (PF = .35)	Non-coded
.7 A	70.7 VAC	Inductive (PF = .35)	Non-coded
2 A	25 VAC	Inductive (PF = .35)	Non-coded

⚠ WARNING

All relay switch contacts are shipped in the standby state (open) state, but may have transferred to the activated (closed) state during shipping. To ensure that the switch contacts are in their correct state, modules must be made to communicate with the panel before connecting circuits controlled by the module.

BEFORE INSTALLING

This information is included as a quick reference installation guide. If the modules will be installed in an existing operational system, inform the operator and local authority that the system will be temporarily out of service. Disconnect the power to the control panel before installing the modules. This system contains static sensitive components. Always ground yourself with a proper wrist strap before handling any circuits so that static charges are removed from the body. The housing cabinet should be metallic and suitably grounded.

NOTICE: This manual should be left with the owner/user of this equipment.

GENERAL DESCRIPTION

The CR-6 Six Relay Control Module is intended for use in an intelligent alarm system. Each module is intended for Form-C switching applications, which do not require wiring supervision for the load circuit. A single isolated set of dry relay contacts is provided for each module, which is capable of being wired for either normally open or nor-

mally closed for each operation. Each module has its own address. A pair of rotary code switches is used to set the address of the first module from 01 to 94. The remaining modules are automatically assigned to the next five higher addresses. Provisions are included for disabling a maximum of three unused modules to release the addresses to be used elsewhere. Each CR-6 module also has panel controlled green LED indicators. The panel can cause the LEDs to blink, latch on, or latch off.

Contents include:

- (6) 1 x 3 Terminal Blocks
- (1) 1 x 4 Terminal Blocks
- (2) 1¹/₄" (32mm) Stand offs
- (4) Machine Screws
- (1) Shunt (**NOTE:** For the disable position, not more than one shunt shall be installed at the same time)
- (2) Nuts

COMPATIBILITY REQUIREMENTS

To ensure proper operation, this module shall be connected to a compatible control panel only.

COMPONENTS

Following are descriptions of the CR-6 mounting frameworks. There are two mounting options for CR-6 modules:

- Up to six CR-6 modules can be installed on a CH-6 in a BB-6 cabinet
- One or two CR-6 modules can be installed in a BB-2 cabinet

Chassis

The CH-6 chassis is used to mount CR-6 modules in a BB-6 cabinet. It accommodates up to six CR-6 modules in a single cabinet row three modules wide and two modules deep.

Figure 1: CH-6 Chassis

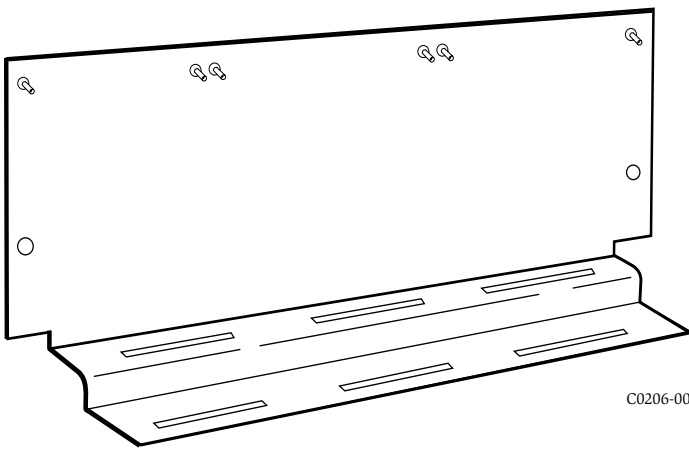

The BB-2 cabinet has a built-in chassis that will accommodate one or two CR-6 modules.

Figure 2: BB-2 Cabinet

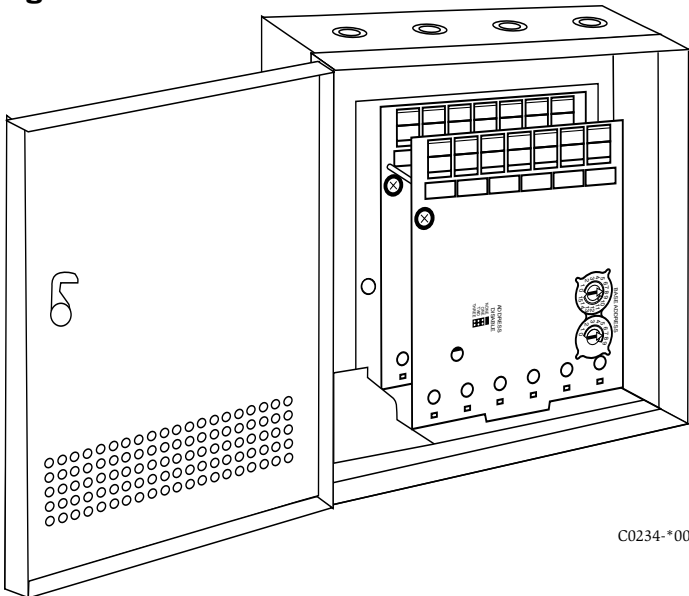

The front CR-6 module positions of each chassis are offset below the rear CR-6 module positions so that all of the status indicators are visible.

Cabinets

A BB-6 cabinet will house the CH-6 chassis with up to six CR-6 modules installed on it.

The BB-2 cabinet houses one or two CR-6 modules on the internal chassis that is part of the cabinet. Refer to cabinet installation documents for dimensions.

INSTALLATION STEPS

1. Cabinet Mounting

Figure 3: Typical mounting hole locations

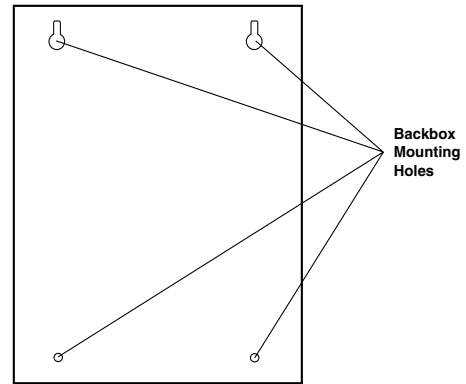

C0235-00

In a clean, dry area, mount the backbox using the four holes provided in the back surface of the cabinet.

2. Chassis Installation

The CH-6 chassis is mounted in the BB-6 cabinet. It is shipped with two self-threading screws, which are used to fasten the chassis to the back wall of the cabinet (see Figure 4).

Figure 4: Mounting the CH-6 chassis

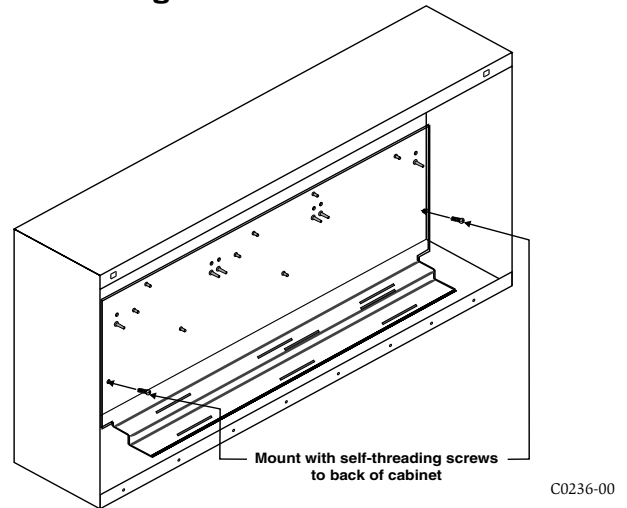

The BB-2 cabinet comes with the chassis already installed, so no mounting is necessary.

3. Module Installation

There are two methods for installing a module in the rear position of a chassis. Method one is for installation of a rear module only, when no module will be installed in front of it. Refer to Figure 5 for instructions. Method two is for installation of a rear module when another module will be installed in the chassis position in front of it. Refer to Figures 6a and 6b for method two. All necessary screws and standoffs are supplied with the modules.

Figure 5: Installation of rear module only, method one

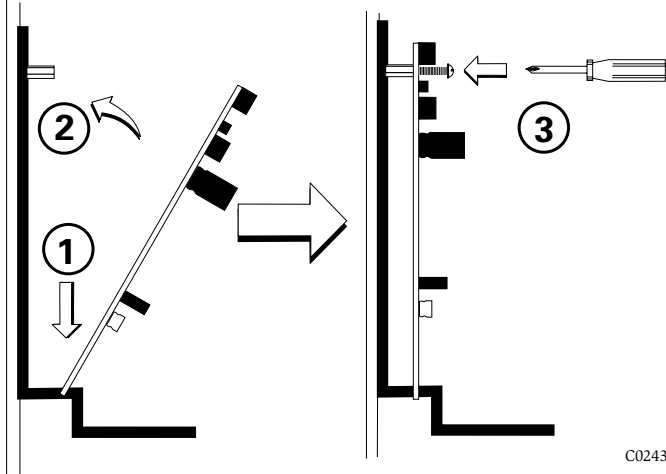

C0243-00

- Step 1: Insert the bottom of the CR-6 module down into a rear slot on the chassis.
- Step 2: Carefully swing the upper edge of the board back towards the back of the chassis until it touches the two standoffs.
- Step 3: Align two 4-40 screws with the two standoffs and tighten.
- Step 4: Address and wire the modules according to the instructions in this manual.

The steps in Figures 6a and 6b describe and illustrate module installation when the rear chassis position and the position in front of it will be filled. Front position installation is possible only if the rear position is filled with an input/output module.

Figure 6a: Installation of CR-6 module in a rear chassis position, method two

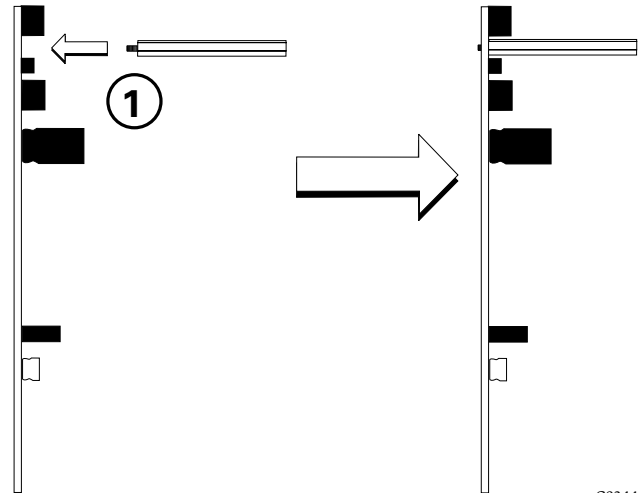

C0244-00

- Step 1: Insert the bottom edge of the CR-6 module down into a rear slot of the chassis.
- Step 2: Carefully swing the upper edge of the board towards the back of the chassis until it touches the short standoff attached to the chassis.
- Step 3: Align the long standoff with the short standoff and tighten.

Figure 6b: Installation of CR-6 module in front chassis position

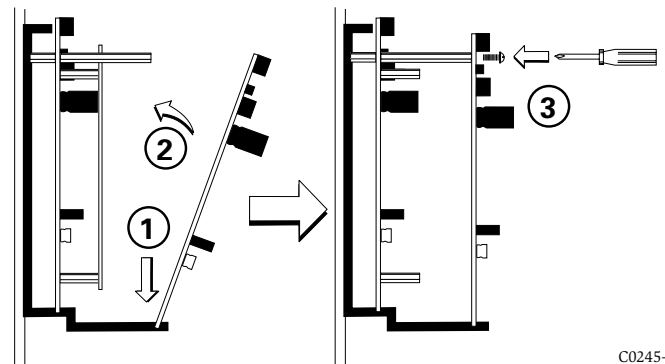

C0245-00

- Step 1: Insert the bottom edge of the CR-6 module down into a front slot of the chassis.
- Step 2: Carefully swing the upper edge of the board towards the back of the chassis until it touches the 1 1/4" (31.75mm) standoffs installed on the rear module.
- Step 3: Align two 4-40 screws with the two standoffs and tighten.
- Step 4: Address and wire the modules according to the instructions in this manual.

WIRING

NOTE: Power must not be applied to the unit when changing functionality of the shunts.

NOTE: All wiring must conform to applicable local codes, ordinances, and regulations.

1. Install module wiring in accordance with the job drawings and appropriate wiring diagrams.
2. Make electrical connections by stripping approximately 1/4" (6.35mm) of insulation from the end of the wire sliding the bare end of the wire under the clamping plate, and tightening the clamping plate screw.
3. Set the address on the modules per the job drawing. Use the rotary code switches to set the address of the first-

module (between 01 and 94). The remaining modules are automatically assigned to the next five higher addresses. For example, if the base address switch is set to 28, the next five modules will be addressed to 29, 30, 31, 32, and 33. DO NOT set the lowest address above 94, as the other modules will be assigned to nonexistent addresses.

4. A shunt is provided to disable a maximum of three unused modules. Modules are disabled from the highest address and work downward. If two modules are disabled, the lowest four addresses will be functional, while the highest two will be disabled. For example, if the shunt for Address Disable is placed on "two" and the base address switch is set to 28, the modules will be assigned to 28, 29, 30 and 31.

Figure 7: Wiring and programming the CR-6 module

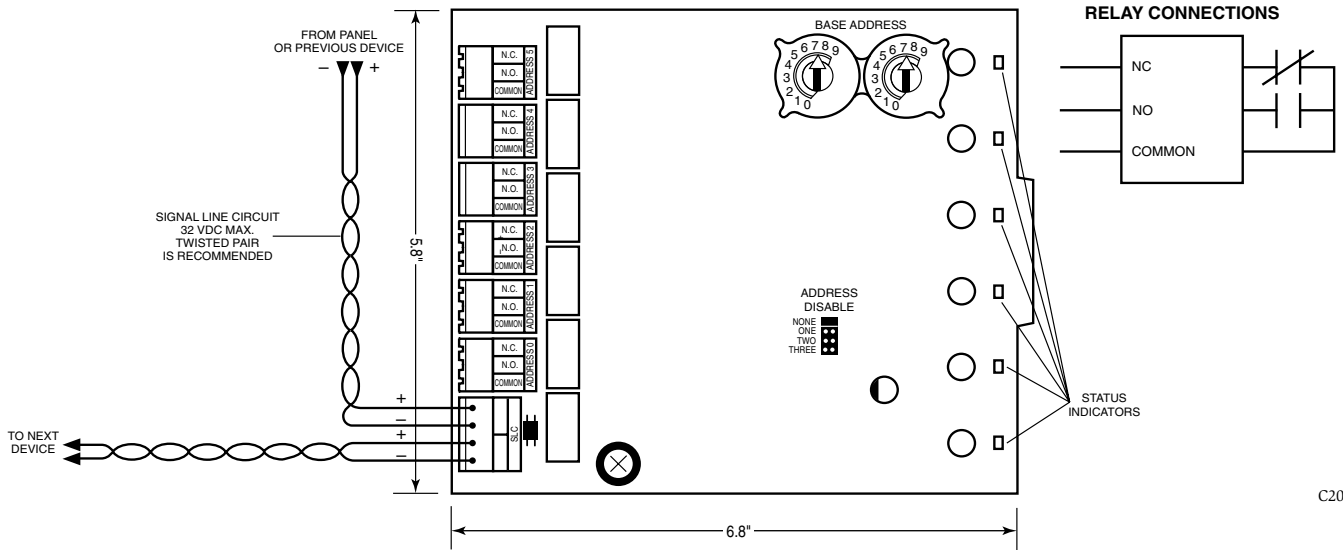

C205-01

NOTES:

- The relay contacts on the CR-6 may be connected to either a power-limited or non power-limited source, this wiring must remain separated by at least 1/4" (6.35 mm) from all power-limited wiring.
- Power-limited circuits must employ type FPL, FPLR, or FPLP cable as required by Article 760 of the NEC.
- For easier wiring, assign all power-limited wiring to one side rather than alternating with non power-limited.

Three-Year Limited Warranty

System Sensor warrants its enclosed air duct smoke detector to be free from defects in materials and workmanship under normal use and service for a period of three years from date of manufacture. System Sensor makes no other express warranty for this air duct smoke detector. No agent, representative, dealer, or employee of the Company has the authority to increase or alter the obligations or limitations of this Warranty. The Company's obligation of this Warranty shall be limited to the replacement of any part of the air duct smoke detector which is found to be defective in materials or workmanship under normal use and service during the three year period commencing with the date of manufacture. After phoning System Sensor's toll free number 800-SENSOR2 (736-7672) for a Return Authorization number, send defective units postage prepaid to:

System Sensor, Returns Department, RA # _____, 3825 Ohio Avenue, St. Charles, IL 60174. Please include a note describing the malfunction and suspected cause of failure. The Company shall not be obligated to replace units which are found to be defective because of damage, unreasonable use, modifications, or alterations occurring after the date of manufacture. In no case shall the Company be liable for any consequential or incidental damages for breach of this or any other Warranty, expressed or implied whatsoever, even if the loss or damage is caused by the Company's negligence or fault. Some states do not allow the exclusion or limitation of incidental or consequential damages, so the above limitation or exclusion may not apply to you. This Warranty gives you specific legal rights, and you may also have other rights which vary from state to state.

FCC Statement

This device complies with part 15 of the FCC Rules. Operation is subject to the following two conditions: (1) This device may not cause harmful interference, and (2) this device must accept any interference received, including interference that may cause undesired operation.

NOTE: This equipment has been tested and found to comply with the limits for a Class B digital device, pursuant to Part 15 of the FCC Rules. These limits are designed to provide reasonable protection against harmful interference in a residential installation. This equipment generates, uses and can radiate radio frequency energy and, if not installed and used in accordance with the instructions, may cause harmful interference to radio communications. However, there is no guarantee that interference will not occur in a particular installation. If this equipment does cause harmful interference to radio or television reception, which can be determined by turning the equipment off and on, the user is encouraged to try to correct the interference by one or more of the following measures:

- Reorient or relocate the receiving antenna.
- Increase the separation between the equipment and receiver.
- Connect the equipment into an outlet on a circuit different from that to which the receiver is connected.
- Consult the dealer or an experienced radio/TV technician for help.