



3825 Ohio Avenue, St. Charles, Illinois 60174  
 800/736-7672, FAX: 630/377-6495  
 www.systemsensor.com

## SC-6 Six Supervised Control Module

### SPECIFICATIONS

Normal Operating Voltage:	15-32VDC
Stand-By Current:	2.25 mA
Alarm Current:	35 mA (assumes all six relays have been switched once and all six LEDs solid on)
Temperature Range:	32°F to 120°F (0°C to 49°C); -10°C to 55°C (For EN54 application only)
Humidity:	10 to 93 % Non-condensing
Dimensions:	6.8"H x 5.8"W x 1.25"D
Accessories:	CH-6 Chassis; BB-2 Cabinet; BB-6 Cabinet
Wire Gauge:	12-18 AWG
Maximum NAC Circuit Line Loss:	4 VDC
Power Rating Per Circuit (Speakers):	63W @ 70.7VAC 50W @ 25VAC
MaxNAC Current Ratings:	For class B wiring system, 3A For class A wiring system, 2A

**Table 1: Short Circuit Protection - UL 864 9th Edition Requirements**

<b>NOTICE TO USERS, INSTALLERS, AUTHORITIES HAVING JURISDICTION, AND OTHER INVOLVED PARTIES</b>			
This product incorporates field-programmable software. In order for the product to comply with requirements in the Standard for Control Units and Accessories for Fire Alarm Systems, UL 864, certain programming features or options must be limited to specific values or not used at all as indicated below.			
<b>Program Feature or Option</b>	<b>Permitted in UL 864 (Y/N)</b>	<b>Possible Settings</b>	<b>Settings Permitted in UL 864</b>
Disabling short circuit protection when a single power supply is shared by multiple NACs	No	Enable or Disable short circuit protection	Enable short circuit protection when a single power supply is shared by multiple NACs. Short circuit protection can be disabled only when a power supply is not shared by multiple NACs.

### BEFORE INSTALLING

This information is included as a quick reference installation guide. Refer to the appropriate control panel installation manual for detailed system information. If the modules will be installed in an existing operational system, inform the operator and local authority that the system will be temporarily out of service. Disconnect the power to the control panel before installing the modules. This system contains static sensitive components. Always ground yourself with a proper wrist strap before handling any circuits so that static charges are removed from the body. The housing cabinet should be metallic and suitably grounded.

**NOTICE:** This manual should be left with the owner/user of this equipment.

### GENERAL DESCRIPTION

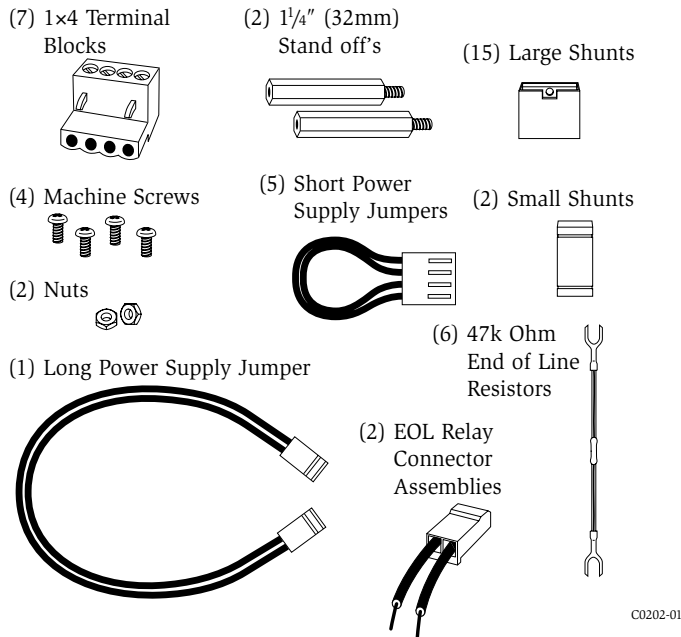
The SC-6 Six Supervised Control Module is intended for use in an intelligent alarm system. Each module is intended for switching applications involving AC, DC, or audio, which require wiring supervision. A common SLC input is used for all modules. Each

module has its own address. A pair of rotary code switches is used to set the address of the first module from 01 to 94. The remaining modules are automatically assigned to the next five higher addresses. Provisions are included for disabling a maximum of three unused modules to release the addresses to be used elsewhere. Each module also has panel controlled green LED indicators. The panel can cause the LEDs to blink, latch on, or latch off.

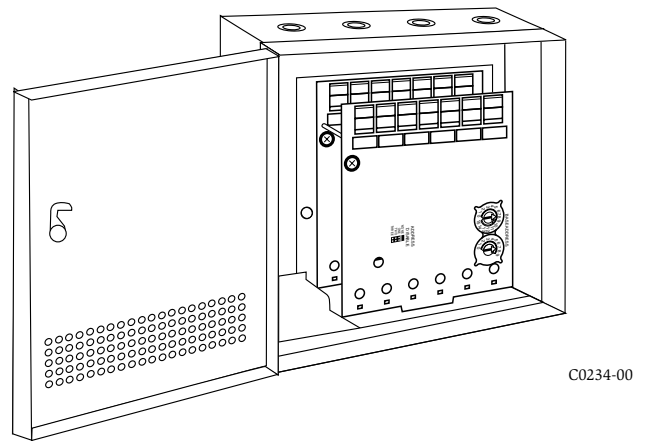
In order to synchronize strobes, horn/strobes, and speaker/strobes, a SYNC-1 accessory card (sold separately) must be used with the SC-6. See the SYNC-1 installation manual for details on how to install.

Each module has terminals for connection to an external supply circuit for powering devices on its NAC.

Each supply must be power limited and its voltage/current limits must be at or below those specified.



**Figure 2: BB-2 Cabinet**



C0234-00

The front SC-6 module positions of each chassis are offset below the rear SC-6 module positions so that all of the status indicators are visible.

**Cabinets**

A BB-6 cabinet will house the CH-6 chassis with up to six SC-6 modules installed on it. Refer to cabinet installation documents for dimensions.

The BB-2 cabinet houses one or two SC-6 modules on the internal chassis that is part of the cabinet. Refer to cabinet installation documents for dimensions.

**INSTALLATION STEPS**

**1. Cabinet Mounting**

In a clean, dry area, mount the backbox using the four holes provided in the back surface of the cabinet (Figure 3).

**2. Chassis Installation**

The CH-6 chassis is mounted in the BB-6 cabinet. It is shipped with two self-threading screws, which are used to fasten the chassis to the back wall of the cabinet (see Figure 4).

There is a short circuit protection monitor for each module. This is provided to protect the external power supply against short circuit conditions on the NAC.

**Included:**

Shipped on Board:

- (1) Small shunt in A/B select position  
(Shipped in Class B position, remove shunt for Class A)
- (6) Large shunts on Enable Power Supply Monitors
- (6) Large shunts on Disable Short Circuit Protection
- (3) Large shunts on Sync Generator

**COMPATIBILITY REQUIREMENTS**

To ensure proper operation, this module shall be connected to a listed compatible control panel.

**COMPONENTS**

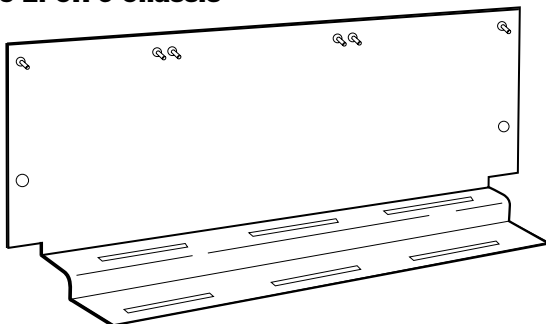
Following are descriptions of the SC-6 mounting frameworks. There are two mounting options for SC-6 modules:

- Up to six SC-6 modules can be installed on a CH-6 in a BB-6 cabinet.
- One or two SC-6 modules can be installed in a BB-2 cabinet.

**Chassis**

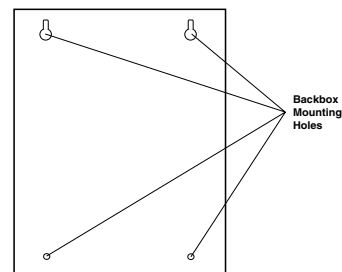
The CH-6 chassis is used to mount SC-6 modules in a BB-6 cabinet. It accommodates up to six SC-6 modules in a single cabinet row three modules wide and two modules deep.

**Figure 1: CH-6 Chassis**



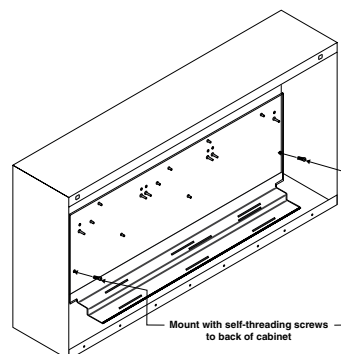
C0202-00

**Figure 3: Typical mounting hole locations**



C0235-00

**Figure 4: Mounting the CH-6 chassis**



The BB-2 cabinet has a built-in chassis that will accommodate one or two SC-6 modules.

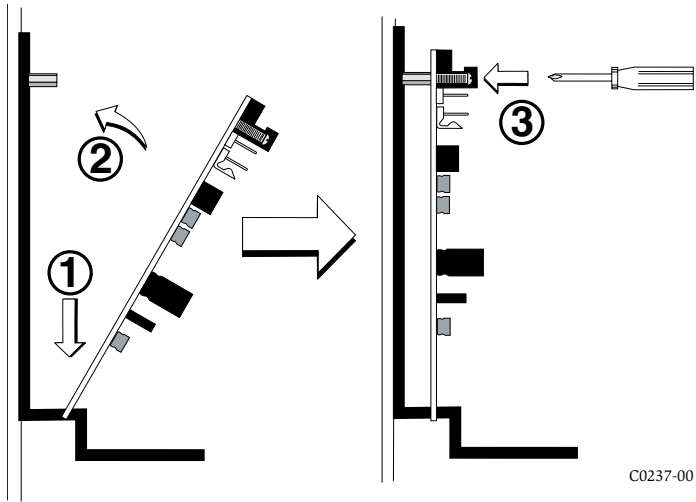
C0236-00

The BB-2 cabinet comes with the chassis already installed, so no mounting is necessary.

### 3. Module Installation

There are two methods for installing a module in the rear position of a chassis. Method one is for installation of a rear module only, when no module will be installed in front of it. Refer to Figure 5 for instructions. Method two is for installation of a rear module when another module will be installed in the chassis position in front of it. Refer to Figures 6a and 6b for method two. All necessary screws and standoffs are supplied with the modules.

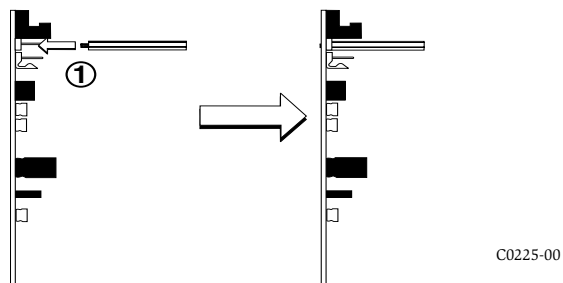
**Figure 5: Installation of rear module only, method one**



- Step 1: Insert the bottom of the SC-6 module down into a rear slot on the chassis.
- Step 2: Carefully swing the upper edge of the board towards the back of the chassis until it touches the two standoffs.
- Step 3: Align two 4-40 screws with the two standoffs and tighten.
- Step 4: Address and wire the modules according to the instructions in this manual.

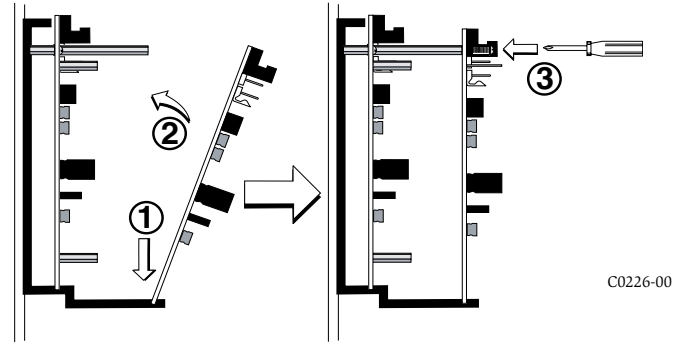
The steps in Figures 6a and 6b describe and illustrate module installation when the rear chassis position and the position in front of it will be filled. Front position installation is possible only if the rear position is filled with another module.

**Figure 6a: Installation of SC-6 module in a rear chassis position, method two**



- Step 1: Insert the bottom edge of the SC-6 module down into a rear slot of the chassis.
- Step 2: Carefully swing the upper edge of the board towards the back of the chassis until it touches the short standoff attached to the chassis.
- Step 3: Align the long standoff with the short standoff and tighten.

**Figure 6b: Installation of SC-6 module in front chassis position**



- Step 1: Insert the bottom edge of the SC-6 module down into a front slot of the chassis.
- Step 2: Carefully swing the upper edge of the board towards the back of the chassis until it touches the 1<sup>1</sup>/<sub>4</sub>" (31.75mm) standoffs installed on the rear module.
- Step 3: Align two 4-40 screws with the two standoffs and tighten.
- Step 4: Address and wire the modules according to the instructions in this manual.

### WIRING

**NOTE:** All wiring must conform to applicable local codes, ordinances, and regulations.

1. Install module wiring in accordance with the job drawings and appropriate wiring diagrams.
2. All wiring to the SC-6 is done via terminal blocks. In order to properly make electrical connections strip approximately 1/4" of insulation from the end of wire, sliding the bare end of the wire under the clamping plate screw.
3. Set the address on the modules per the job drawing. Use the rotary code switches to set the address of the first module (between 01 and 94).

In Class B operation, the remaining modules are automatically assigned to the next five higher addresses. For example, if the base address switch is set to 28, the next five modules will be addressed to 29, 30, 31, 32, and 33.

In Class A operation, a maximum of three Class A circuits are available. For example, if the base address switch is set to 28, 30 and 32 will be automatically assigned to the modules while 29, 31 and 33 are available to be used for other modules on the SLC. For Class A and B operation, DO NOT set the lowest address above 94, as the other modules will be assigned to nonexistent addresses.

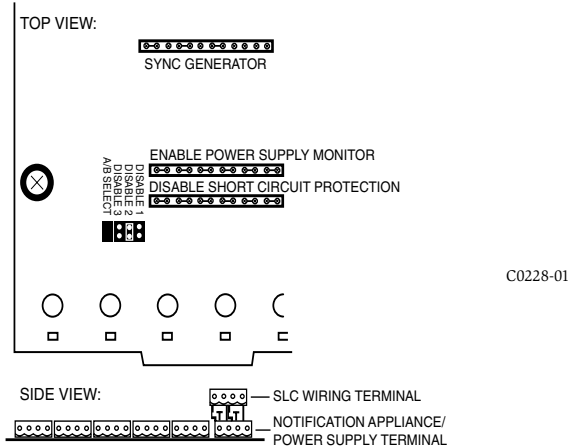
4. A shunt is provided to disable a maximum of three unused modules (see Figure 7). Modules are disabled from the highest address and work downward. If two modules are disabled, the lowest four addresses will be functional, while the highest two will be disabled. For example, if the shunt for Address Disable is placed on "two" and the base address switch is set to 28, the modules will be assigned to 28, 29, 30 and 31, disabling the higher two positions.

**NOTE:** In Class A operation, placing the small shunt on "disable 3" will disable all three addresses. Placing the small shunt on "disable 2" will disable two out of the three addresses. For example, if the address switch is set to 28 and the small shunt is placed on "disable 2", addresses 30 and 32 will be disabled while address 28 will be enabled.

- There is a short circuit protection option for each address. The board is shipped with short circuit protection disabled for each address represented by six large shunts on the “Disable Short Circuit Protection” area. To enable short circuit protection for an address, remove the corresponding shunts from the “Disable Short Circuit Protection” area. When enabled, the module will not switch power supply if a short circuit condition exists on a notification appliance circuit.

**NOTE:** Short circuit protection may only be enabled if power supply monitoring is enabled.

**Figure 7:**



- There is a power supply monitor that must be enabled to facilitate short circuit protection (see Figure 7). The module is shipped with power supply monitoring enabled represented by six large shunts on the pins of the “Enable Power Supply Monitor” area.

**NOTE:** Power supply monitoring should not be used for audio applications. The short circuit protection feature is also not available for audio applications.

**NOTE:** The XP6-C does not provide ring back when used as a firefighter telephone circuit.

**NOTE:** This feature is not for use with all Fire Alarm Control Panels. Please consult with Technical Services before enabling this feature.

**NOTE:** Place unused shunts on single pin to store on board for future use.

**NOTE:** SLC wiring is the top terminal block, notification appliance/power supply is the bottom.

**NOTE:** Power must not be applied to the unit when changing functionality of the shunts.

**NOTE:** Whether in Class B or Class A wiring, power supply monitoring and short circuit protection must be enabled on the NAC circuits that are sharing a power supply.

**NOTE:** Short circuit protection can only be disabled if a power supply is not being shared by multiple NACs.

## WIRING NOTES

- Power-limited circuits must employ type FPL, FPLR, or FPLP cable as required by Article 760 of the NEC.
- For easier wiring, assign all power-limited wiring to one side of the enclosure rather than alternating with non power-limited.

## NAC Wiring and Supervision

For Class B, Style Y applications (figures 8, 9, and 12 are typical): connect the positive terminal of the notification appliance(s) to the NAC+ terminal and the negative device terminal to the adjacent NAC- terminal. Connect one (for each NAC) of the supplied EOL resistors across the NAC+ and NAC- wires, at the ends farthest away from the NAC terminal of the SC-6.

For Class A, Style Z applications (figures 10, 11, and 13 are typical) wire the NACs per table 2. The A/B select shunt must be removed prior to connecting the SC-6 to the SLC. The EOL resistors should not be used. The SC-6 is capable of supporting 3 Class A, Style Z NACs. The SC-6 will only respond at the base address, base address + 2, and base address + 4 (assuming no addresses have been disabled).

**TABLE 2**

NAC#	(+) CONNECTIONS	(-) CONNECTIONS
+0	+0 NAC+, +1 NAC+, NOTIFICATION APPLIANCE+	+0 NAC-, +1 NAC- NOTIFICATION APPLIANCE-
+2	+2 NAC+, +3 NAC+, NOTIFICATION APPLIANCE+	+2 NAC-, +3 NAC- NOTIFICATION APPLIANCE-
+4	+4 NAC+, +5 NAC+, NOTIFICATION APPLIANCE+	+4 NAC-, +5 NAC- NOTIFICATION APPLIANCE-

## Power Supply Wiring and Supervision

Table 3 gives an overview of how the power connectors, T0–T5 and T10–T15, are interconnected by the circuit board (PCB). The external supply connection points, at T0–T5, are marked by PS- and PS+ on the PCB legend. Pin 1 is indicated by a dot next to T10–T16. The odd pins, on T10–T16, always connect to PS- pins (e.g. PS-, of the +0 NAC, is connected to T10-1 and T11-1). The even pins always connect to PS+ pins (e.g. PS+, of the +5 NAC, is connected to T15-4 and T16-2).

**TABLE 3**

PS OR NAC NUMBER (TERMINAL / PINS)	TERMINAL / PINS
+0 (T0 – BOTTOM / PS- & PS+)*	T10 / 1 & 2, T11 / 1 & 2
+1 (T1 / PS- & PS+)	T11 / 3 & 4, T12 / 1 & 2
+2 (T2 / PS- & PS+)	T12 / 3 & 4, T13 / 1 & 2
+3 (T3 / PS- & PS+)	T13 / 3 & 4, T14 / 1 & 2
+4 (T4 / PS- & PS+)	T14 / 3 & 4, T15 / 1 & 2
+5 (T5 / PS- & PS+)	T15 / 3 & 4, T16 / 1 & 2

\*NOTE: T0–TOP is reserved for SLC connections only (see Figure 8).

All power supplies, external to the cabinet (in which the SC-6 is housed), should be connected to T0–T5 which are suitable connectors for field wiring. The 1 x 4 terminal blocks, shown on page 1, should be used to make these connections.

All NACs can be wired to be powered by separate external supplies (figures 8 and 10 are typical), or a single supply (figures 9 and 11 are typical) can be shared among multiple NACs. If a supply is to be shared, between NACs wired to a common PCB, use the short power supply jumpers shown on page 1. The jumpers can be used on T11–T15. Refer to Table 4 for jumper functions.

**When multiple (2 or more) NAC circuits share a power supply, the wiring for the power supply must be in conduit and 20 feet or less from the SC-6 board.**

**TABLE 4**

JUMPER LOCATION	NAC PAIR SHARING SUPPLY
T11*	+0 and +1
T12	+1 and +2
T13*	+2 and +3
T14	+3 and +4
T15*	+4 and +5

\*Note: Jumpers must be placed on T11, T13 and T15 for all Class A, Style Z applications.

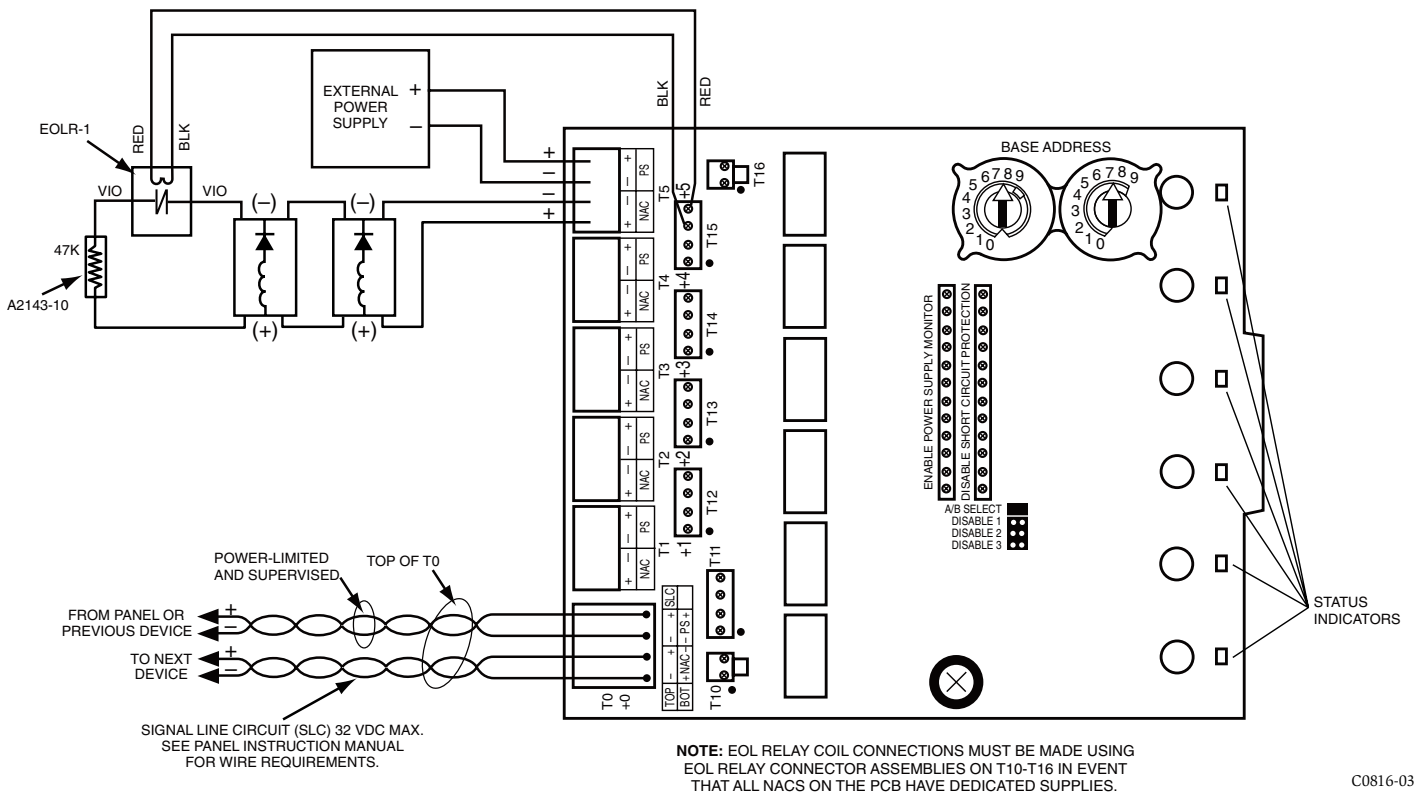
A supply can be wired to be shared among multiple PCBs in the same cabinet (figure 14 is typical). To share among multiple PCBs: use the long power supply jumpers (shown on page 1) to connect either T10 or T16, of one PCB, to either T10 or T16 of the other PCB.

An EOL relay must be used for every external power supply (figures 8-11 are typical). The EOL relay coil should always be connected at the external power supply input of the module which

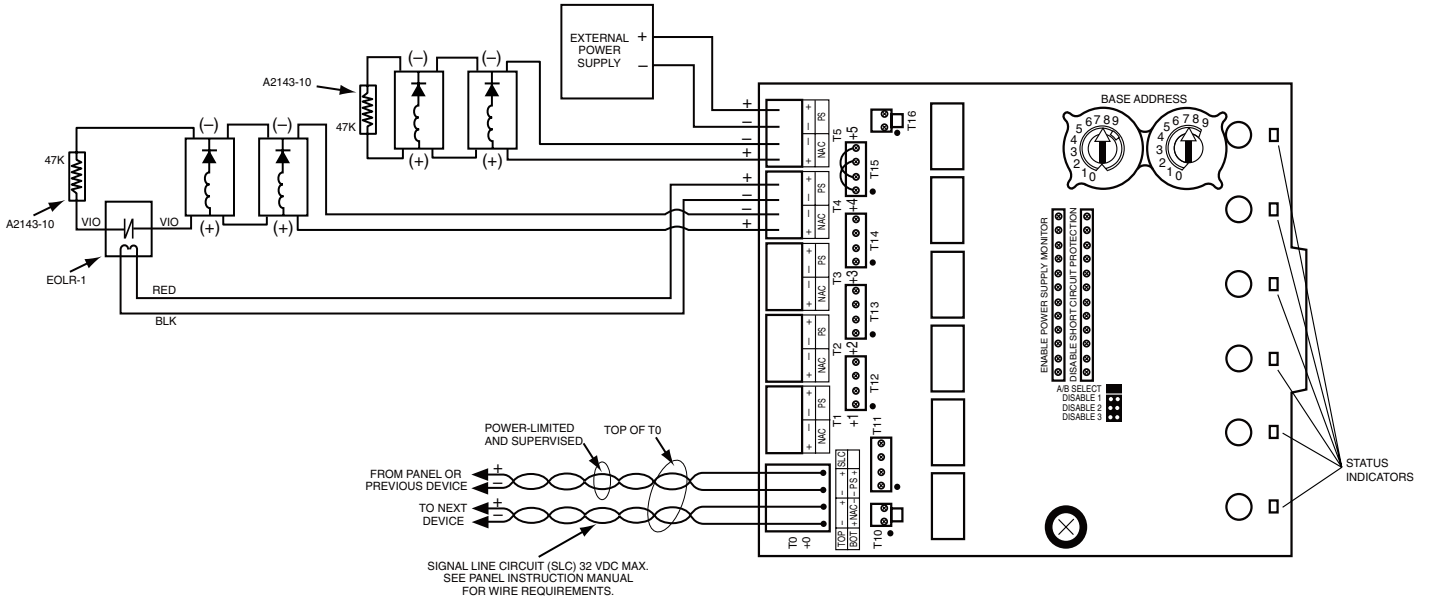
is connected to the ends of the wires which are farthest from the power supply. The EOL relay contacts should always be connected in series with the NAC wiring of the same module. The EOL relay coil should be connected across the PS+ (red wire) and PS- (black wire) if it is connected at T0 – T5. The EOL relay coil should be connected across adjacent pins (red – even pin#, black – odd pin#), of the same connector, if T10 – T16 are used. If the supply is an audio amplifier then the points, where the EOL relay coil would normally be connected, should be connected to the amplifier supervision EOL device (figures 12 and 13 are typical).

All wiring must be in accordance with the NEC, NFPA 72 and all other applicable codes and standards. All external power supplies must be voltage regulated with battery back-up. All external power supplies, audio amplifiers, EOL relays, and notification appliances must be UL listed for fire protection signaling applications.

**Figure 8: Example of Class B, Style Y NAC configuration with a single supply dedicated to a single NAC.**

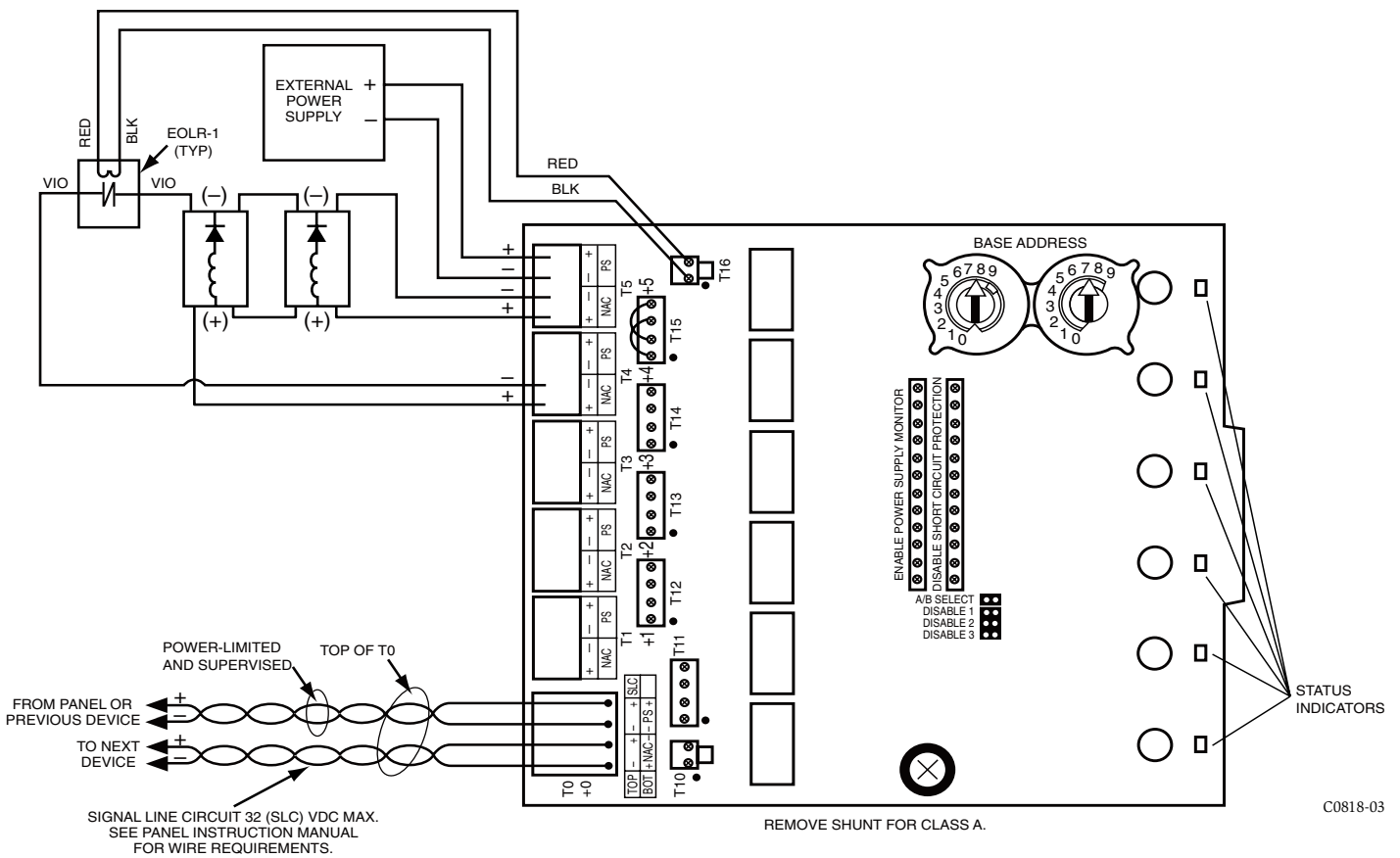


**Figure 9: Example of Class B, Style Y NAC configuration with a single supply shared by 2 NACs.**



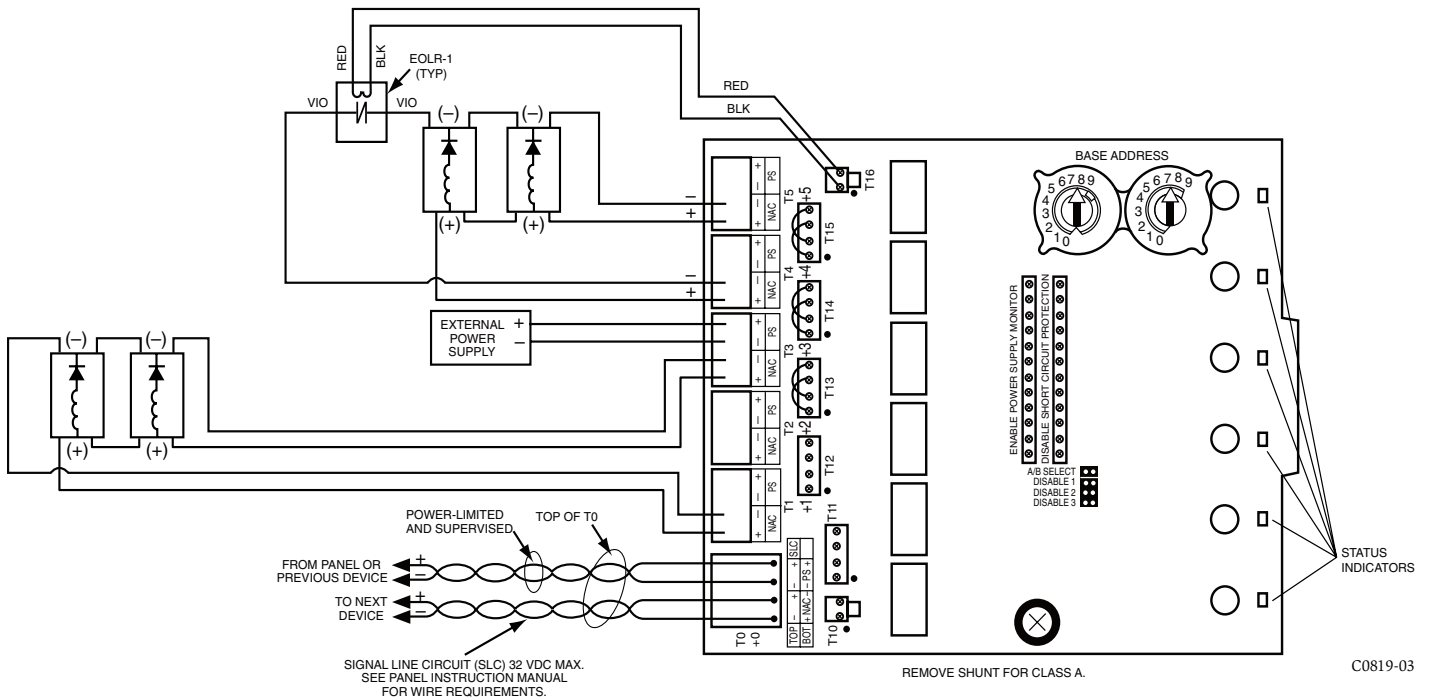
C0817-03

**Figure 10: Example of Class A, Style Z NAC configuration with a single supply dedicated to a single NAC.**

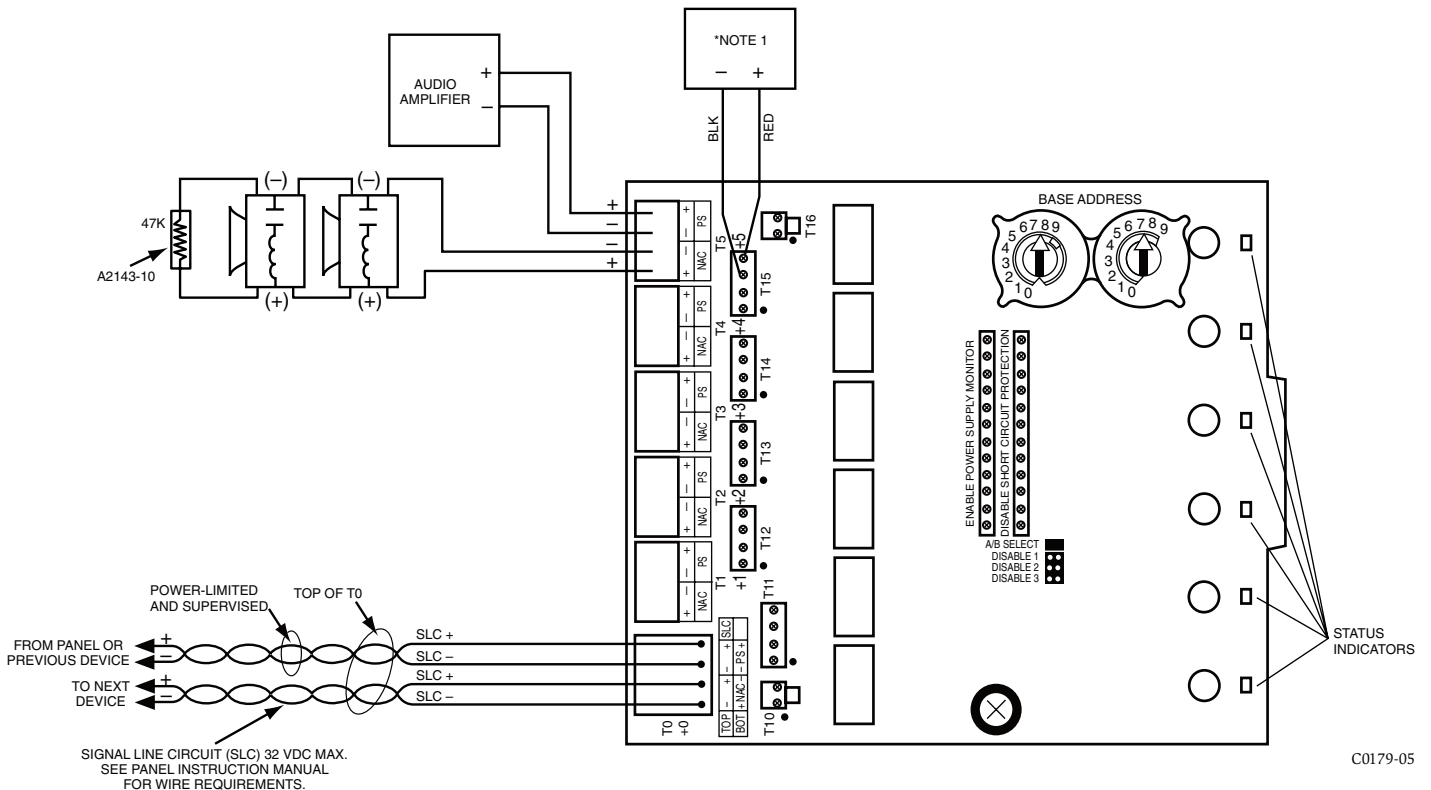


C0818-03

**Figure 11: Example of Class A, Style Z NAC configuration with a single supply shared by 2 NACs.**



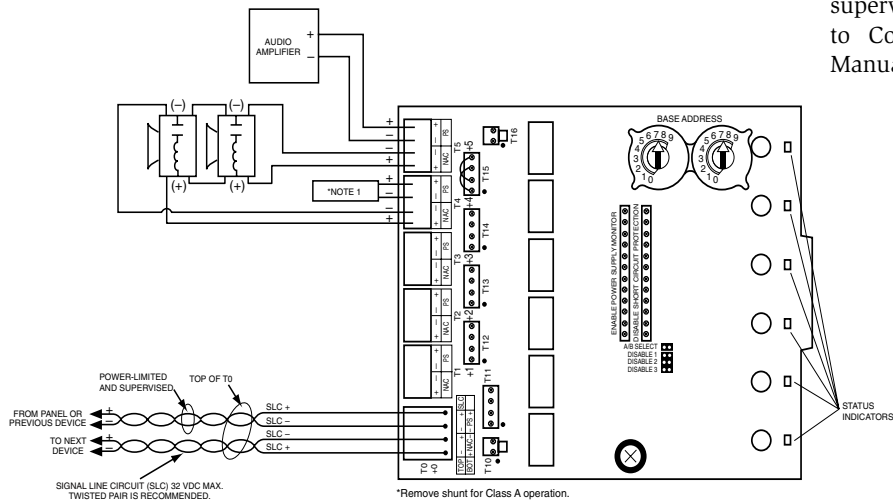
**Figure 12: Example of Class B, Style Y Audio NAC configuration.**



\* NOTE: To audio amplifier supervision EOL device. Refer to Control Panel Installation Manual for wiring instructions

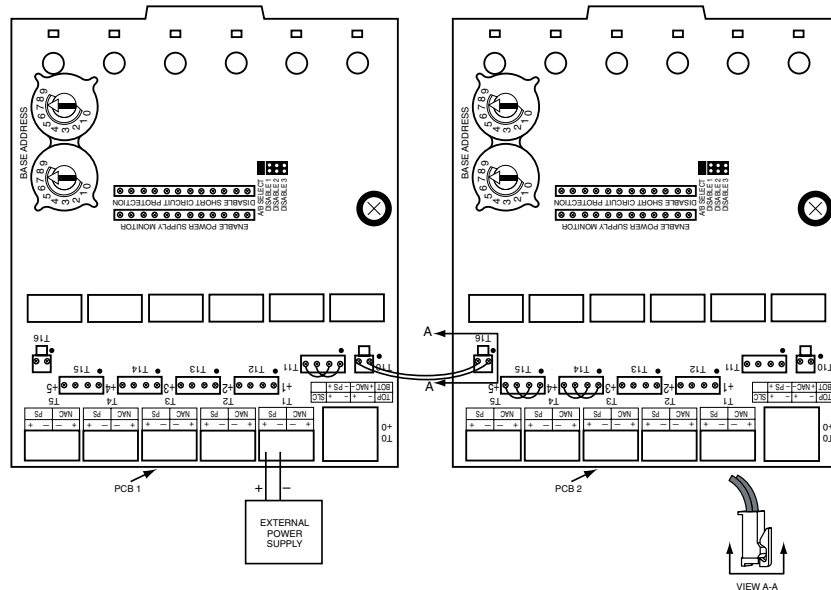
**Figure 13: Example of Class A, Style Z Audio NAC configuration.**

\*NOTE: To audio amplifier supervision EOL device. Refer to Control Panel Installation Manual for wiring instructions



C0238-01

**Figure 14: Example of multiple boards sharing same external supply. Supply is shared by NACs +0 and +1 (on PCB 1) as well as +3, +4, and +5 (on PCB 2). Refer to figures 9–12 for typical NAC wiring. Make certain lip on long power supply jumper engages retaining tab on T10 or T16 as shown in View A-A.**



C0203-00

**FCC Statement**

This device complies with part 15 of the FCC Rules. Operation is subject to the following two conditions: (1) This device may not cause harmful interference, and (2) this device must accept any interference received, including interference that may cause undesired operation.

**NOTE:** This equipment has been tested and found to comply with the limits for a Class B digital device, pursuant to Part 15 of the FCC Rules. These limits are designed to provide reasonable protection against harmful interference in a residential installation. This equipment generates, uses and can radiate radio frequency energy and, if not installed and used in accordance with the instructions, may cause harmful interference to radio communications. However, there is no guarantee that interference will not occur in a particular installation. If this equipment does cause harmful interference to radio or television reception, which can be determined by turning the equipment off and on, the user is encouraged to try to correct the interference by one or more of the following measures:

- Reorient or relocate the receiving antenna.
- Increase the separation between the equipment and receiver.
- Connect the equipment into an outlet on a circuit different from that to which the receiver is connected.
- Consult the dealer or an experienced radio/TV technician for help.

**Three-Year Limited Warranty**

System Sensor warrants its enclosed air duct smoke detector to be free from defects in materials and workmanship under normal use and service for a period of three years from date of manufacture. System Sensor makes no other express warranty for this air duct smoke detector. No agent, representative, dealer, or employee of the Company has the authority to increase or alter the obligations or limitations of this Warranty. The Company's obligation of this Warranty shall be limited to the replacement of any part of the air duct smoke detector which is found to be defective in materials or workmanship under normal use and service during the three year period commencing with the date of manufacture. After phoning System Sensor's toll free number 800-SENSOR2 (736-7672) for a Return Authorization number, send defective units postage prepaid to:

System Sensor, Returns Department, RA # \_\_\_\_\_, 3825 Ohio Avenue, St. Charles, IL 60174. Please include a note describing the malfunction and suspected cause of failure. The Company shall not be obligated to replace units which are found to be defective because of damage, unreasonable use, modifications, or alterations occurring after the date of manufacture. In no case shall the Company be liable for any consequential or incidental damages for breach of this or any other Warranty, expressed or implied whatsoever, even if the loss or damage is caused by the Company's negligence or fault. Some states do not allow the exclusion or limitation of incidental or consequential damages, so the above limitation or exclusion may not apply to you. This Warranty gives you specific legal rights, and you may also have other rights which vary from state to state.