

M500M-4-20

4-20mA Analog Input Module

3825 Ohio Avenue, St. Charles, Illinois 60174
 1-800-SENSOR2, FAX: 630-377-6495
 www.systemsensor.com

SPECIFICATIONS

SLC	
Normal Operating Voltage:	15 to 32 VDC
Maximum Current Draw:	9.3 mA (LED on)
Average Operating Current:	1 mA (LED flashing)
External Supply	
Normal Operating Voltage:	24 VDC Nominal
Standby Current:	10 mA
Maximum Current:	510 mA
Initiating Device	
Maximum Current:	500 mA
Temperature Range:	-10°C to 60°C
Humidity:	10% to 95% Non-condensing
Dimensions:	4 1/2" H x 4" W x 1 1/4" D (Mounts to a 4" square by 2 1/8" deep box.)
Accessories:	SMB500 Electrical Box

BEFORE INSTALLING

This information is included as a quick reference installation guide. Refer to the control panel installation manual for detailed system information. If the modules will be installed in an existing operational system, inform the operator and local authority that the system will be temporarily out of service. Disconnect power to the control panel before installing the modules.

NOTICE: This manual should be left with the owner/user of this equipment.

GENERAL DESCRIPTION

The M500M-4-20 4-20mA Analog Input Module is intended for use in intelligent, two-wire systems, where the individual address of each module is selected using the built-in rotary switches. This module allows intelligent panels to interface and monitor two-wire or three-wire sensors, that produce a 4-20mA signal output. It transmits the status (normal, open, or alarm) of one sensor back to the control panel. The M500M-4-20 has a panel controlled LED indicator. Only one sensor can be connected to the M500M-4-20.

COMPATIBILITY REQUIREMENTS

To ensure proper operation, this module shall be connected to a listed compatible system control panel only.

MOUNTING

The M500M-4-20 mounts directly to 4-inch square electrical boxes (see Figure 1). The box must have a minimum depth of 2 1/8 inches. Surface mounted electrical boxes (SMB500) are available from System Sensor.

WIRING

NOTE: All wiring must conform to applicable local codes, ordinances, and regulations. This module is intended for powerlimited wiring only.

1. Install module wiring in accordance with the job drawings and appropriate wiring diagrams.
2. Set the address on the module per job drawings.
3. Secure module to electrical box (supplied by installer), as shown in Figure 1.

FIGURE 1. MODULE MOUNTING:

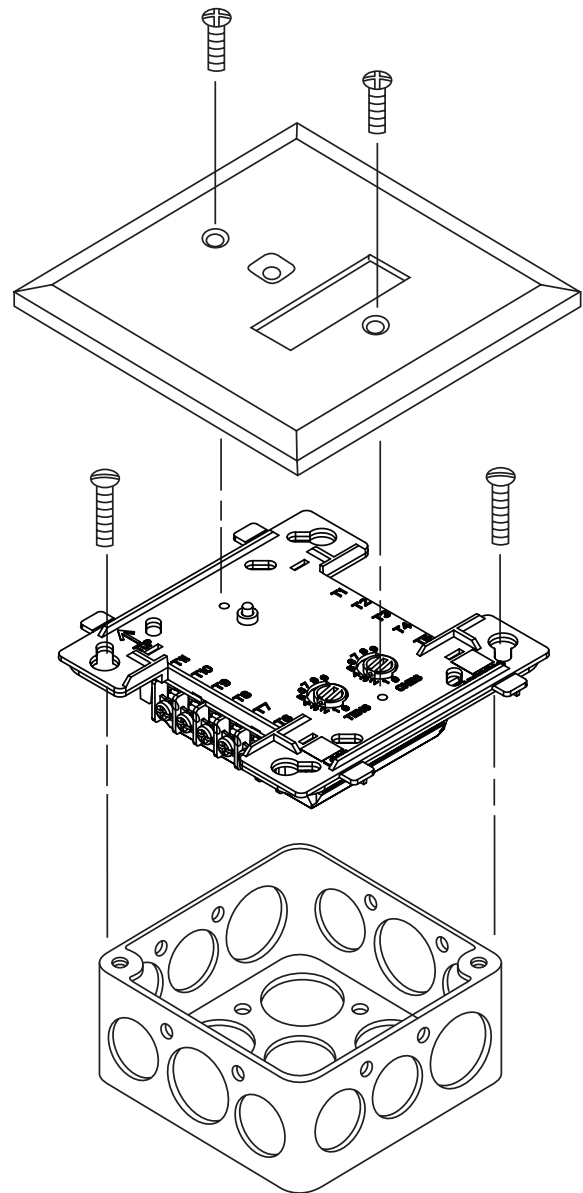
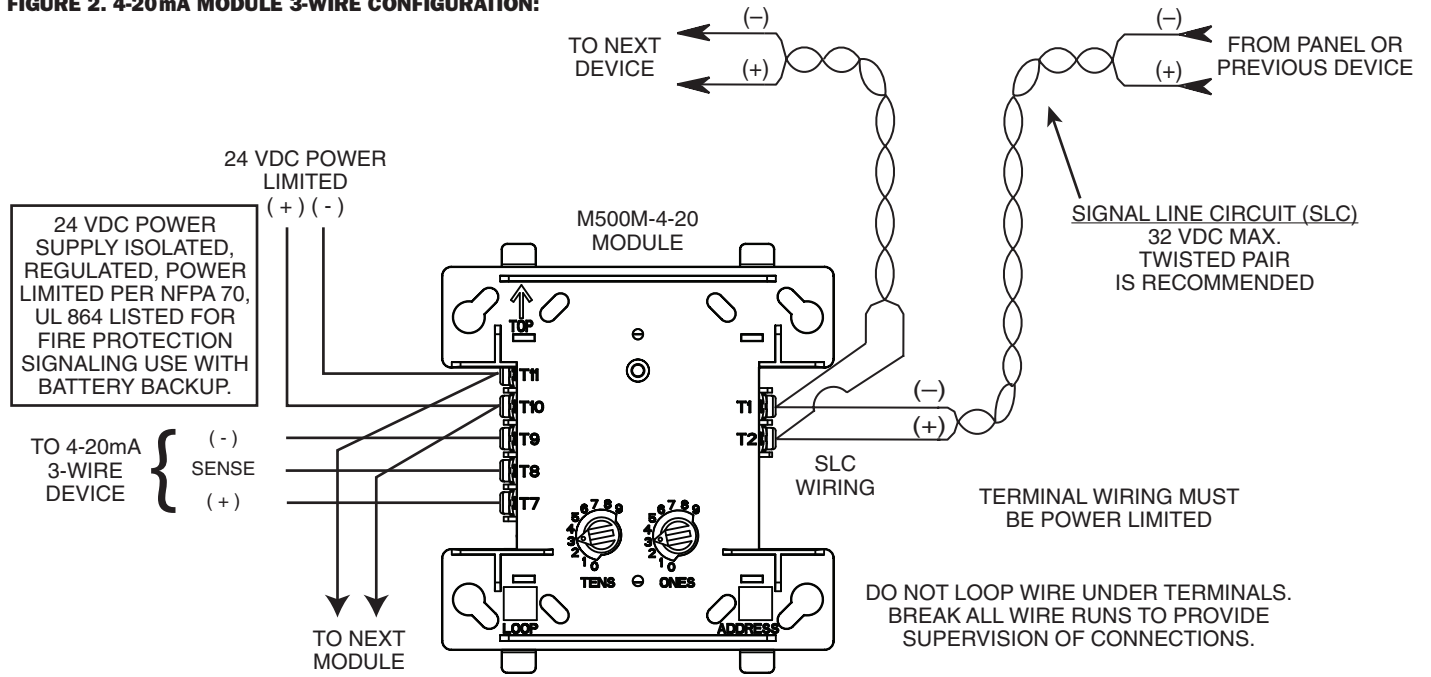
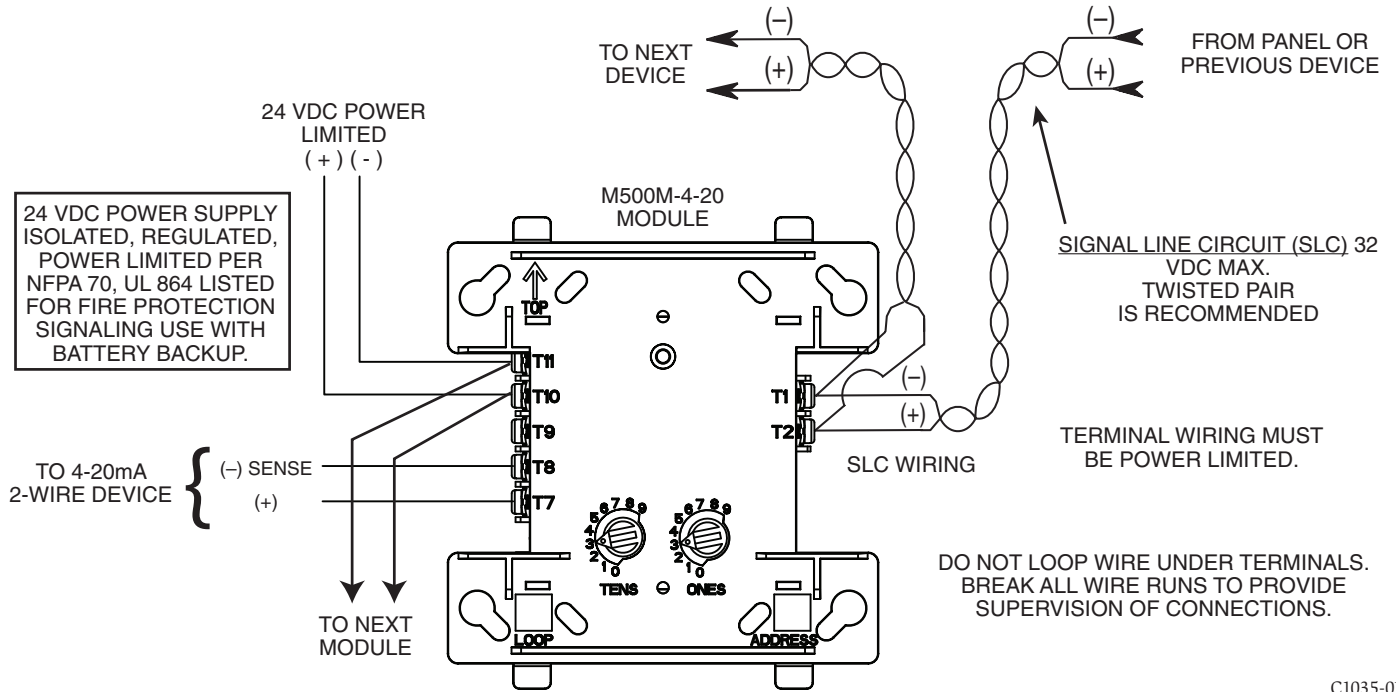

FIGURE 2. 4-20mA MODULE 3-WIRE CONFIGURATION:



C1034-01

FIGURE 3. 4-20mA MODULE 2-WIRE CONFIGURATION:



C1035-01