



3825 Ohio Avenue, St. Charles, Illinois 60174
 1-800-SENSOR2, FAX: 630-377-6495
 www.systemsensor.com

OSYEXP Explosion Proof Gate Valve Supervisory Switch

Specifications

Contact Ratings:	One SPDT (Form C) Switch 15 A @ 125/250/480 VAC; 1/8 HP @ 125 VAC, 1/4 HP @ 250 VAC 1/2 A @ 125 VDC; 1/4 A @ 250 VDC
Dimensions:	7" L X 3.125" D X 4.875" H
Maximum Stem Extension:	2.875"
Bracket Span:	7"
Operating Temperature Range:	-40° - 160°F (-40°C - 71°C)
Shipping Weight:	2-1/4 lb.
Enclosure Rating:	UL Listed explosion proof switch enclosure for use in hazardous locations. Class I, Groups C and D; Class II, Groups E, F and G

Important

Please Read Carefully And Save

This manual contains important information about the installation and operation of supervisory switches. These instructions apply to System Sensor switches for outside screw and yoke valves only. Read all instructions carefully before beginning installation.



To prevent ignition of hazardous atmospheres, disconnect supply circuit before opening. Keep assembly tightly closed when in operation. Do NOT leave unused wires exposed.

All supervisory switch installations must comply with local codes and ordinances and the requirements of the authority having jurisdiction. Additional information is available in National Fire Protection Association standards NFPA 13, 13D, 13R, 71, and 72.

General Installation Considerations

The OSYEXP Supervisory Switch can be mounted on open yoke valves between 1/2" and 12" in diameter. The switch is designed to supervise the open condition of the OS & Y Gate Valve in hazardous locations.

All OSYEXP models are equipped with a ground screw inside the switch housing for those applications where grounding is required.

Narrow Yoke Valves

As Figure 1 suggests, installing the valve with mounting bolts inside the yoke is recommended. However, some valves may have yokes that are too narrow for this arrangement. If this is the case, the bolts can be positioned on the outside of the yoke.

Limited Clearance Valves

The OSYEXP mounting bracket fits most of the open yoke valves used in fire protection systems. However, some of these valves, especially those less than 1 1/2" in diameter, have irregularly shaped yokes or such limited clearances that the clamping bar cannot be installed properly and/or it causes the valve to bind. If this is the case, the use of the supplied J-bolts is required to attach the OSYEXP to the valve (see J-Bolt Detail, Figure 1).

Installation Procedure

See Figures 2 and 3, as required, while performing the procedure that follows.

Perform step 1 on valves 1 1/2" in diameter and smaller only. Proceed directly to step 2 if the switch is being installed on a valve larger than 1 1/2" in diameter.

1. Remove and discard the two C-clips and roller from the actuating lever.
2. Set the valve to its fully open position. Remove the OSYEXP Supervisory Switch from the carton and adjust the position of the retaining washers to provide sufficient bolt length for the yoke thickness of the valve.

Figure 1:

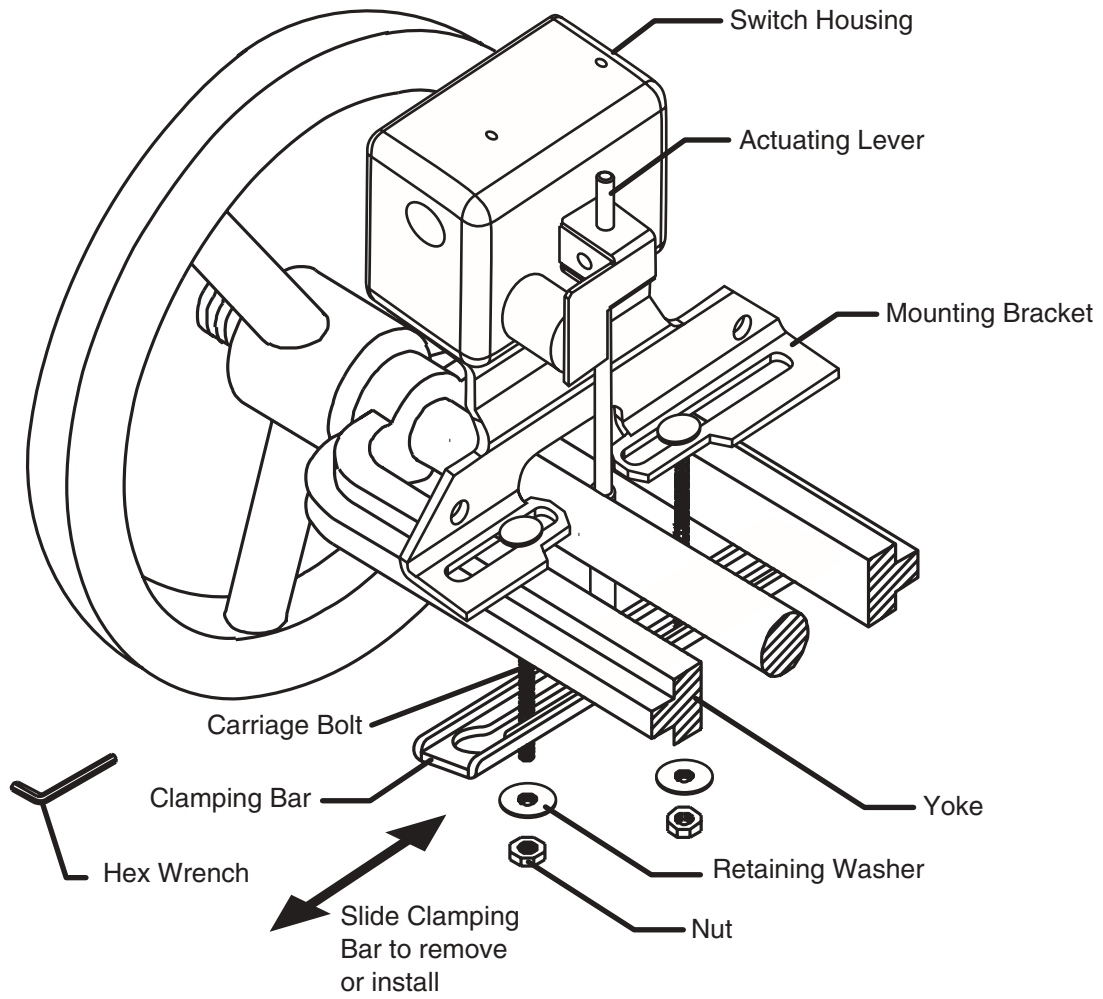

W0182-00

NOTE:

Larger gate valve shown (2" through 12"). When installing supervisory switch to smaller gate valves ($\frac{1}{2}$ " through $1\frac{1}{2}$ "), carriage bolts are to be located on outboard side of yoke. On small valves with limited clearance, J-bolts may be used.

J-Bolt Detail:

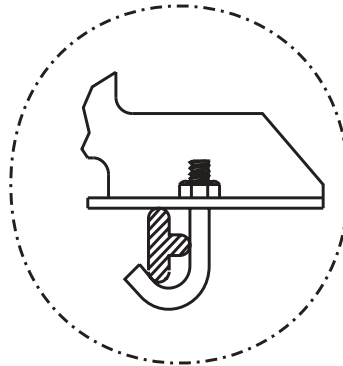

W0207-00

Figure 2:

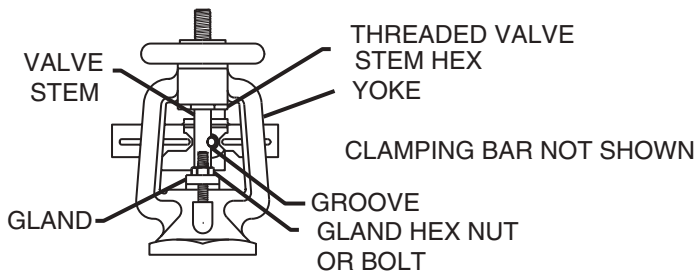

W0209-00

Position the switch on the valve with the bolts on the inside (preferably) or outside of the yoke, depending on clearances. Adjust the position of the OSYEXP as far as possible from the valve gland and in a location where the actuating lever contacts the unthreaded section of the valve stem (if the valve stem is already grooved, proceed directly to step 6).

3. When the switch is in position on the valve, slide the open end of the clamping bar onto the bolts and under the retaining washers. If necessary, adjust the length of the actuating lever by loosening the lever screw. The lever is properly adjusted when it clears the clamping bar. Tighten the nuts by hand and slide the OSYEXP until the switch trip point is found as the lever rests on the valve stem. This approximates the final position of the OSYEXP after the valve stem is grooved. Carefully check all clearances of the bolts, actuator, mounting bracket, clamping bar, and OSYEXP cover. Adjust the position as necessary. If clearance is a problem, refer to the Limited Clearance Valves (page 1) section of this manual.
4. Mark the point on the valve stem where the actuating lever contacts the valve stem.
5. Remove the OSYEXP by loosening the nuts and sliding the clamping bar from beneath the retaining washers. Remove the OSYEXP from the valve and set it aside.

(a) Valves 1/2" in diameter and smaller only.

Use a 1/2" untapered round file to file a groove 3/32" deep in the valve stem at the mark that was made in step 4. Be sure to remove any burrs resulting from the filing to avoid damaging the valve stem packing gland.

(b) Valves larger than 1/2" inches in diameter only.

Use a 3/8" untapered round file to file a groove 1/8" deep in the valve stem at the mark that was made in step 4. Be sure to remove any burrs resulting from the filing to avoid damaging the valve stem packing gland.

6. Mount the switch loosely with the actuating lever centered in the groove. When the switch is in position on the valve, slide the open end of the clamping bar onto the bolts and under the retaining washers, as indicated in Figure 1.
7. Ensure that the actuating lever does not hit the clamping bar at any point in its travel. If it does, adjust the length of the lever by loosening the lever screw, sliding the lever in or out, as needed, and retightening the screw.
8. Adjust the supervisory switch position on the valve so that the switch is open when the actuating lever is in the groove with the valve in the full open position. The circuit should close when the valve is closed 1/5 of its travel or 2 full turns of the handle, whichever is less. The switch produces an audible "click" when it closes. The switch closure can also be tested electrically by using an ohmmeter to test for continuity between its terminals.
9. Tighten the nuts securely with a wrench and check the operation of the OSYEXP as in step 8. If necessary, reposition the OSYEXP and test it again.
10. Wire the supervisory switch as shown in Figure 3.
NOTE: When removing the cover of the OSYEXP use provided allen wrench in box.
11. Replace the OSYEXP cover.
12. Test the operation of the OSYEXP by closing the valve the 1/5 of its travel distance or two full turns, whichever is less. The circuit should indicate a closure during this procedure. If it does not, readjust the supervisory switch and actuator positions until the switch closes when the valve is operated.

Testing

Test the operation of all supervisory switches before they are placed into service and at least semiannually, or as required by the authority having jurisdiction.

NOTE: Notify the proper authorities that the supervisory switch(es) is (are) undergoing maintenance and, therefore, will be temporarily out of service. Disable the system or zone undergoing testing to prevent unwanted alarms.

Test the operation of the OSYEXP by closing the valve the 1/5 of its total travel distance or two full turns, whichever is less. A contact closure must occur during this procedure. If it does not, readjust the supervisory switch and actuator positions until the switch closes when the valve operated.

Figure 3. Supervisory switch wiring diagram:

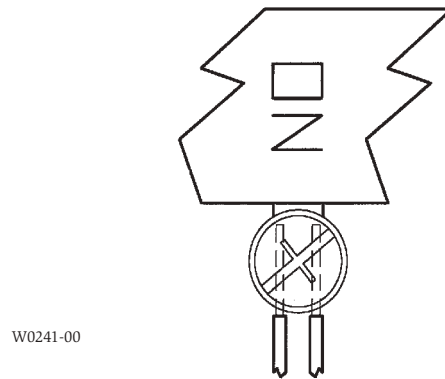
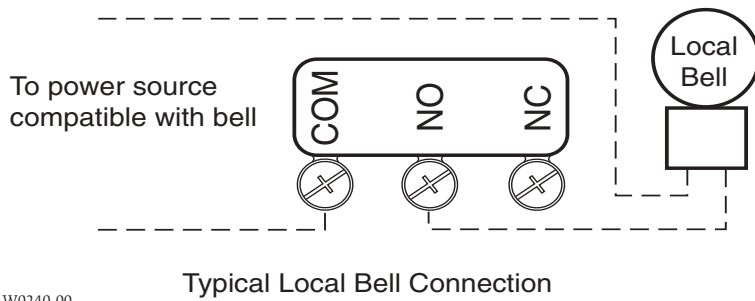
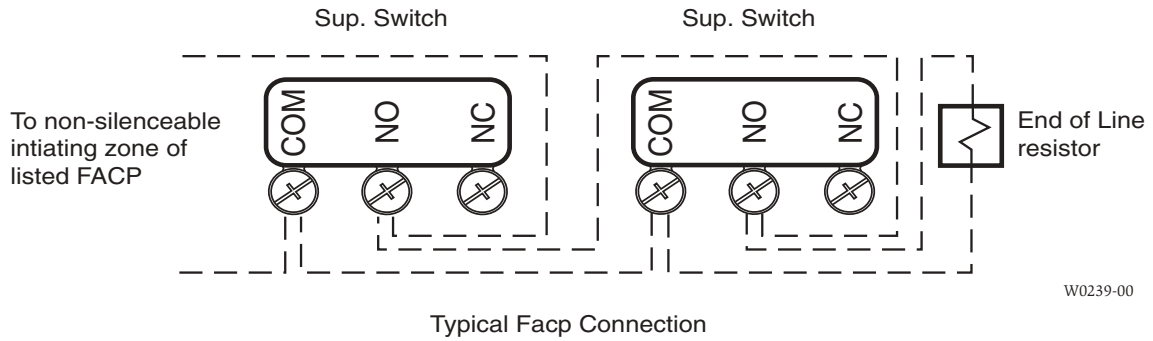

Break wire as shown for supervision of connection. DO NOT allow stripped wire leads to extend beyond switch housing. DO NOT loop wires.

▲WARNING

The Limitations of Supervisory Switch Alarm Devices

1. Alarms generated by the actuation of the activating lever may not be received by a central station if telephone or other communication lines to the detector are out of service, disabled, or open.
2. Supervisory switch alarm devices have a normal service life of 10-15 years.
3. Supervisory switches are not a substitute for insurance. Building owners should always insure property and lives being protected.

Please refer to insert for the Limitations of Fire Alarm Systems

Three-Year Limited Warranty

System Sensor warrants its enclosed pressure switch to be free from defects in materials and workmanship under normal use and service for a period of three years from date of manufacture. System Sensor makes no other express warranty for this pressure switch. No agent, representative, dealer, or employee of the Company has the authority to increase or alter the obligations or limitations of this Warranty. The Company's obligation of this Warranty shall be limited to the repair or replacement of any part of the pressure switch which is found to be defective in materials or workmanship under normal use and service during the three year period commencing with the date of manufacture. After phoning System Sensor's toll free number 800-SENSOR2 (736-7672) for a Return Authorization number, send defective units postage prepaid to: System Sensor, Return

Department, RA # _____, 3825 Ohio Avenue, St. Charles, IL 60174. Please include a note describing the malfunction and suspected cause of failure. The Company shall not be obligated to repair or replace units which are found to be defective because of damage, unreasonable use, modifications, or alterations occurring after the date of manufacture. In no case shall the Company be liable for any consequential or incidental damages for breach of this or any other Warranty, expressed or implied whatsoever, even if the loss or damage is caused by the Company's negligence or fault. Some states do not allow the exclusion or limitation of incidental or consequential damages, so the above limitation or exclusion may not apply to you. This Warranty gives you specific legal rights, and you may also have other rights which vary from state to state.